NIMS Machining Level I Preparation Guide

Milling

Table of Contents

Overview	page 2 - 5
• Introduction	page 2
• Who Wrote the Questions	page 2
• How to Prepare for the Credentialing Exam	page 3
• Areas of Knowledge Measured by the Exam	pages 3, 4
• Before the Exam	page 5
• At the Testing Site	page 5
Machining Exam – Milling	pages 6 - 31
• Exam Content and Sample Question Overview	page 6
• Task Specifications	page 7
• Task List	pages 7 - 25
• Sample Exam	pages 8 - 26
• Answer Key	pages 26 - 31

Overview

Introduction

This preparation guide or test advisor is intended to help machinists study and prepare for the National Institute for Metalworking Skills (NIMS) written credentialing exam. The sample test will help prepare machinists to take the actual credentialing exam. None of the questions are duplicates from the actual exam. However, this preparation guide is a useful for reviewing technical knowledge and identifying areas of strength and deficiency needed so that the student has what is needed to do well on the exam.

Achieving a NIMS credential is a means through which machinists can prove their abilities to themselves, to their instructors or employers and to the customer. By passing the NIMS credentialing exam, you will earn a valuable and portable credential. Because the test is challenging, you will have the satisfaction of proving to yourself and others that you have reached a level of competency that is accept nationally.

Who Wrote the Questions

A panel of technical experts, from all areas of the metalworking industry, wrote the questions used on the actual credentialing exam. The panel of experts ranged from company presidents and owners, to engineers and quality personnel, to actual working machinists. Exam questions are designed to test the knowledge skills needed for entry-level machinists. They are written to deal with practical problems, computations, and decisions machinists encounter in their day-to-day work.

The technical experts must first validate the exam questions. Then, before the questions become part of the credentialing exam, qualified machinist and industry personnel again validate them on a national level. Rejected questions are then rewritten or discarded altogether.

How to Prepare for the Credentialing Exam

Become familiar with the exam content and question format by utilizing the tools provided in this test preparation guide. The **Exam Specifications** portion contained in this guide contains a summary description of the content covered by the actual credentialing exam. The **Task List** describes competencies for each particular area associated with the credentialing area.

Each question on the sample test is linked to a particular task or set of tasks found in the **Task List**. Therefore, a review of the **Task List**, with an eye on judging whether you know how to perform each task listed, will provide you with valuable information as you prepare for the exam.

The questions are multiple-choice. Note instructions that may accompany some questions. Be sure to read each question carefully (twice, if necessary) so that you know exactly what is being asked. Check each answer and your work since an error in computation or understanding may make a wrong answer appear correct.

The following four steps are suggested for effective preparation:

- Step 1: Study the content list for each exam you will attempt.
- Step 2: Carefully read the **Task List** for each section.
- Step 3: Review the sample test to become familiar with subject matter and question type. This is a very important step.
- Step 4: Repeat steps 1 through 3 and identify the area(s) where you need additional study. Use the preparation guide as a self-diagnostic tool.

Areas of Knowledge Measured by the Exam

The knowledge and skills you will need to pass the credentialing exam are as follows:

Exam Sections

The exam is divided into four major sections. They are:

- **Drilling Operations on a Vertical Milling Machine**
- **Milling Operations**
- **Quality Control and Inspection Tasks**
- **Workpiece Clamping and Tool Holding**

Following is a list of the basic knowledge areas assessed by the exam.

- **Applying the *Machinery's Handbook*:** The machinist must be able to reference and applying information found in the handbook to solve applied problems. Referencing thread percentage, tap drill diameters, speeds, feeds and cutting tool parameters are some of the skills required.
- **Basic Mathematics:** The exam will assess basic math knowledge of fraction/decimal conversion, addition and subtraction of decimals and an understanding of percentage. Processing basic formulas to solve for the given known or another part of the formula is an additional skill required for this module.
- **Vertical Milling Machine Components:** The exam presents questions asking the student to identify components of vertical milling machines. Students must be able to identify essential components, their functions and basic machine adjustments.
- **Threads and Tapping:** Specific areas of knowledge include an understanding of tap drill charts and thread percentage, tapping lubricants, tap drills for pipe threads and taps used for specific operations. The machinist must be able to troubleshoot basic tapping and threading problems.
- **Safety Practices:** Areas of knowledge includes knowledge of basic safety, cutting tool safety and basic machine maintenance and housekeeping. Students must know some elementary first aid procedures they can perform on themselves.
- **Milling Operations Setup:** The student must know the procedure for adjusting the mill head to be perpendicular to the table (trammig). Other areas of importance includes center various details or shapes and the proper procedure for utilizing center-finding tools. The importance of layout lines and machining to the lines as well as the application of the sine bar are included.

Before the Exam

Try to be well rested for the exam. Being well rested will make you more alert and efficient when taking the credentialing exam. Review any course material from your instructor. Review the test advisor information and sample test. Bring at least two sharpened (#2) soft leaded pencils and an eraser. In addition, bring a calculator and the *Machinery's Handbook*. Become familiar with the procedure for taking a Scantron test. If you wish to pace yourself, bring a watch, or be aware of the location of clocks at the test site. Make sure to bring some form of identification, any necessary paperwork from NIMS and arrive at the test site at least 10 to 15 minutes prior to the specified exam time.

At the Testing Site

When you arrive at the test center, wait in the assigned area until the proctor begins the test orientation and administration. The proctor will instruct you in the proper procedure for filling out any information on the answer sheet and will tell you the amount of time allotted for the exam, reference materials that can be used and if a calculator is permissible.

Once the exam has begun, keep track of time. Avoid spending too much time on any one question. Answer the questions you know the answers to and then go back those you have difficulty with if time allows. Repeat this process for each section. Again, do not spend an excessive amount of time on any one question.

It is to your advantage to answer every question. Do not leave any answers blank. Answers that are left blank will be counted as incorrect. Your score will be based on the number of correct answers.

Exam Content and Sample Question Summary

Exam Content and Sample Question Overview

The following material is designed to help machinist prepare for and obtain a NIMS credential in the area of Milling. This section begins with an **Exam Specifications** section. The **Exam Specifications** will list the main categories covered on the exam. This section will also list the name of the topic, the number of questions pertaining to that topic, and the percentage of the exam devoted to that topic.

The **Task List** describes competencies a machinist must have in order to receive a credential for Milling. The **Task List** has a two-fold purpose. The first purpose is to prepare the machinist for credentialing. The second is to encourage instructors to apply the **Task List** as a measurement of the effectiveness of their curricula.

The number of questions in each content area may not be equal to the number of tasks listed. Some of the tasks are more complex and broader in scope. This type of information may be covered by several questions. Other tasks are simple and narrow in scope and one question may cover several tasks. The main objective in listing the tasks is to describe accurately what is done on the job, not to make each task correspond to a particular exam question.

Sample questions follow the **Task List**. Although these same questions will not appear on the actual exam, they are in the same format as the actual exam questions. All questions on the credentialing exam are in the multiple-choice format. Some concepts evaluated on the credentialing exam are assessed in greater depth with the sample test questions. The sample test questions are developed to test conceptual knowledge of machining rather than specific competencies. The sample test is longer than the actual credentialing exam.

Answers to the sample questions are located at the end of the sample test. Work with your instructor to identify weak areas and evaluate answers. Use the sample test as a study guide and diagnostic tool.

Exam Specifications – Milling

Content Area	No. of Questions	% of Test
Measurement Practices	4	7.9
Drilling Operations	2	3.9
Feeds and Speeds	2	3.9
Safety Practices	3	6.0
Tapping	2	3.9
Basic Milling Operations	1	1.9
Clamping and Vise Applications	2	3.9
Milling Operations Setup	2	3.9
Milling Machine Components	3	6.0
Process Improvement	2	3.9
Tool Holding Applications	4	7.9
	Total of 51	100 %

Task List and Sample Questions

Milling

Reading this **Task List** will allow the machinist to focus preparation on those subject areas that need attention. The instructor can use the **Task List** to fine-tune the curricula to meet the standards. If you feel comfortable with your knowledge about a particular task, you are probably ready to answer the questions on that subject matter. If, on the other hand, you have any doubts, you and your instructor can work on these areas to build up proficiencies. Many texts and resources are available to provide information on subject areas.

Measurement Practices

- Proper measuring procedure for measuring a part being held in a vise on the mill table
- Proper measuring instrument(s) for measuring the width of a milled slot
- Criteria to apply when choosing a measuring instrument to inspect a part
- Applying gage pins
- Measuring counterbore depth and diameter
- Measuring surface finish
- Criteria for determining when a part is rejected
- Procedures and tools used for semi-precision and precision layout

1) Surface finish can be measured in:

- a) Millimeters
- b) Microinches
- c) Kilomicrons
- d) Centiinches

2) Surface finish can be checked with a:

- a) Comparison chart
- b) Toolmaker microscope
- c) Eye loupe
- d) Depth micrometer

3) The depth of a 3/8-inch diameter counterbore can best be measured with a:

- a) Dial caliper
- b) Dial test indicator
- c) Gage pins
- d) Depth micrometer

-
- 4) Productions parts are considered rejected when:
 - a) The process plan is changed
 - b) The production run continues through two shifts
 - c) Dimensions are out of tolerance
 - d) All the dimensions are made to the print tolerances

 - 5) The width of a milled slot, hole diameter or counterbore depth can best be measured with a/an:
 - a) Outside micrometer
 - b) Dial test indicator
 - c) Inside micrometer
 - d) Dial caliper

 - 6) Which of the following criteria determines the choice of a measuring instrument when checking a dimension?
 - a) The machine tool used to produce the feature
 - b) The tolerance of the dimension being inspected
 - c) Availability of calibration standards
 - d) The measuring skills of the operator

 - 7) The process of checking and adjusting a measuring instrument to an acceptable standard is called:
 - a) Reliability
 - b) Calibration
 - c) Repeatability
 - d) Discrimination

 - 8) The dimension of a hole is stated as $9/16 \pm 1/64$ inches. Which of the following statements is true if a 0.584-inch diameter pin slips into the hole?
 - a) The hole is oversize
 - b) The hole is to size
 - c) The hole is undersize
 - d) A fractional hole cannot be measured with pins

-
- 9) Which of the following measuring instruments can measure both the depth and diameter of a counterbore?
- a) Inside micrometer
 - b) Outside micrometer
 - c) Depth micrometer
 - d) Dial caliper
- 10) Which of the following describes the safest procedure for measuring a part on the milling machine?
- a) Raise the table and check the dimension
 - b) Stop the machine, deburr, brush chips clear, check the dimension
 - c) Raise the tool, check the dimension, deburr, blow chips off the table
 - d) Take the part out of the machine, deburr, brush chips clear, stop the machine
- 11) Which of the following instruments is used for precision layout?
- a) Scale and scribe
 - b) Combination set and scribe
 - c) Dial indicator height gage and scribe attachment
 - d) Machinist square, scale and scribe

Drilling Operations

- Purpose of counterboring a hole
- Drilling procedures and tool holding devices for drilling operations on a vertical mill
- Point angle for general drilling
- Proper drilling practice when breaking through with the drill
- Proper center finding device for locating a prick punched hole
- Most common drilling practice
- Advantage of drilling on a vertical mill instead of the drill press

-
- 12) The included angle on the point of a general purpose drill is:
- a) 118°
 - b) 39.5°
 - c) 59°
 - d) 135°
- 13) Identify the appropriate drilling operation for cutting a recess for a socket head cap screw:
- a) Counterboring
 - b) Spotfacing
 - c) Countersinking
 - d) Recessing
- 14) Identify the appropriate drilling operation for cutting a recess for a flat head screw:
- a) Spotfacing
 - b) Countersinking
 - c) Counterboring
 - d) Trepanning
- 15) Which of the following is the most common drilling practice?
- a) Counterboring
 - b) Reaming
 - c) Drilling holes
 - d) Lapping
 - e) Countersinking
- 16) To prevent large burrs and a tendency for the drill to grab, a machinist should _____ the spindle pressure when breaking through the material.
- a) Increase
 - b) Vary
 - c) Decrease
 - d) Maintain

-
- 17) Which of the following are advantages of drilling on a milling machine instead of drill press?
- a) The milling machine is capable of greater accuracy
 - b) The milling machine has greater rigidity
 - c) The milling machine is less expensive than purchasing a drill press
 - d) All of the above
 - e) Only a and b
- 18) Which of the following best describes the procedure for drilling a hole?
- a) Layout, center drill, prick punch, countersink, drill
 - b) Drill, center drill, layout, countersink, prick punch
 - c) Layout, prick punch, center drill, drill, countersink
 - d) Countersink, center drill, drill, layout, prick punch
- 19) Identify the center finding device used to line up a center or prick punched hole?
- a) Center drill
 - b) Machining center
 - c) Cone pointed edge finder
 - d) Wiggler
- 20) The most commonly used holding device for a drill applied on a vertical mill is a:
- a) Drill chuck
 - b) Collet properly fit to the straight shank portion of the drill
 - c) Style A toolholder
 - d) Tailstock attachment

Feeds and Speeds

- Variable for selecting cutting speed
- Proper procedure for changing the rpm on vertical mill with a variable speed head
- Application of the feed formula for milling (finding various variables of the formula)
- Correct rotation of a left hand and right hand end mill (viewed from the front end or cutting edge portion)
- Application of the rpm formula for milling
- Other variables that affect cutting speed

21) Which metal removal variable has the greatest affect on tool life?

- a) Depth of cut
- b) Cutting speed (SFM)
- c) Feed rate
- d) Lubrication

22) The cutting speed (in surface feet per minute) is determined by:

- a) The type of material being machined
- b) The size of the vertical milling machine
- c) The rigidity of the workholding device
- d) Number of cutting edges on the tool

23) The correct RPM for a 0.750 diameter high speed steel end mill machining O1 tool steel at 50 sfm is:

- a) 533 RPM
- b) 266.7 RPM
- c) 133.3 RPM
- d) 150 RPM

-
- 24) A right-hand end mill rotates _____ in the spindle and _____ when viewed from the front end (cutting edges).
- a) Counterclockwise, clockwise
 - b) Clockwise, clockwise
 - c) Clockwise, counterclockwise
 - d) Counterclockwise, counterclockwise
- 25) Feed rates for milling operations are expressed as _____.
- a) Inches per revolution
 - b) Feet per minute
 - c) Meters per millimeter
 - d) Inches per minute
- 26) Calculate the feed in inches per minute for O1 tool steel with a cutting speed of 55 SFM. The HSS end mill has a diameter of 0.875 inches with four flutes. The chip load per tooth is 0.008 inches.
- a) 8.05 IPM
 - b) 601.6 IPM
 - c) 17.86 IPM
 - d) 296.51 IPM
- 27) A CNC milling machine uses a feed rate given in inches per revolution (IPR). What is the feed in inches per revolution for a four fluted end mill with a recommended chip load per tooth of 0.014 inches?
- a) 0.014 IPR
 - b) 0.028 IPR
 - c) 0.042 IPR
 - d) 0.056 IPR

-
- 28) Changing the spindle RPM on a vertical milling machine with a belt and pulley drive differs from changing the spindle RPM on a machine with a variable speed drive because the:
- Variable speed drive must be adjusted while the machine is running while the belt and pulley drive requires complete disassembly of the motor and pulley
 - Variable speed drive must be adjusted while the machine is running while the belt and pulley drive requires adjustment while the machine is stopped
 - Variable speed drive must be adjusted while the machine is stopped while the belt and pulley drive requires adjustment while the machining is running
 - Variable speed drive must be adjusted with differential gearing while the machine is stopped and a belt and pulley drive requires no differential gearing

Safety Practices

- Safe approach angle for a cutter when entering the workpiece
- Fire hazard potential of oily rags and wipes (spontaneous combustion)
- Basic safety rules and procedures when operating the milling machine such as never reaching over a revolving cutter, adjust the work only when the cutter is stopped, etc.
- Handling and disposal of coolants, lubricants and cleaning fluids
- Basic first aid if a material (solid) becomes lodged in the eye

- 29) Proper disposal of oily rags and wipes prevents fires by preventing:
- Aqueous emulsion
 - Spontaneous response
 - Spontaneous combustion
 - Aqueous oxidation

-
- 30) Removing any part of the Fire Triangle extinguishes the fire. The three components of the Fire Triangle are:
- a) Oxygen, hydrogen, fuel
 - b) Heat, hydrogen, ashes
 - c) Oxygen, fuel, heat
 - d) Heat, fuel, water
- 31) Which of the following statements is **not** considered a safe practice when operating a vertical milling machine?
- a) Using a brush to clear away chips
 - b) Stopping the machine before taking any measurements
 - c) Climb milling on a mill without backlash control
 - d) Never reaching over a revolving cutter
 - e) Using the speeds and feeds appropriate for the machine rigidity
- 32) Handling solvents, lubricants and cleaning fluids properly maintains a safe work area. A document used as a reference for handling these materials is a:
- a) Failure Mode Effects Analysis (FMEA)
 - b) Control plan
 - c) Maintenance schedule
 - d) Material Safety Data Sheet (MSDS) information
- 33) If solid material becomes lodged in the eye, the first step for proper first aid is to:
- a) Use a magnet to attract the material out of the eye
 - b) Rub the eye in a circular motion
 - c) Pull the top lid over the bottom lid
 - d) Close the eyelid and rub from left to right to dislodge the material

-
- 34) Which of the following is considered a safe practice for a milling cutter or face mill when approaching the workpiece?
- a) Enter the workpiece at a high rate of speed
 - b) A face mill taking a cut of at least 1/2 to 2/3 of the diameter
 - c) Climb milling on a vertical mill that has no backlash control
 - d) Plunge cutting with a four fluted gashed end mill
- 35) What is the first aid procedure for control bleeding for a minor cut?
- a) Apply a tourniquet
 - b) Apply pressure to a pressure point on the body
 - c) Apply a cotton pad to the wound
 - d) Apply pressure to the wound and seek further first aid

Tapping

- Tap drill charts and thread percentage
 - Cutting fluids used on various metals
 - Lubrication for cast iron
 - Referencing tap drill diameters for various NPT pipe threads
 - Types of taps commonly found in a tap set
 - Basic causes of tap breakage
 - Type of tap to finish tapping a blind hole for maximum full thread engagement
- 36) The tap drill for a 3/8-16 UNC internal thread is _____ inches in diameter and provides a _____ thread engagement.
- a) 0.356, 90%
 - b) 0.3125, 75%
 - c) 0.257, 65%
 - d) 0.375, 100%

-
- 37) The optimum thread percentage that most tap drill charts are based on is:
- a) 75%
 - b) 65%
 - c) 55%
 - d) 85%
- 38) The type of tap that is best suited for finish tapping a blind hole is a:
- a) Taper tap
 - b) Plug tap
 - c) Bottoming tap
 - d) Blind hole tap
- 39) What is the proper procedure for tapping under power on a vertical milling machine?
- a) Use the rpm for milling, lock the quill and reverse the motor
 - b) Use a low rpm, leave the quill unlocked, use both the forward and reverse motions of the motor
 - c) Use 150 rpm for all tapping, lock the quill, use both the forward and reverse motions of the motor
 - d) Use 350 rpm for all tapping exceeding 1/4 inch, leave the quill unlocked, use only the forward motion of the motor
- 40) The best cutting fluid for tapping aluminum is:
- a) Heavy duty soluble oil
 - b) Sulfur based chlorinated oil
 - c) Mineral spirits
 - d) No fluid at all
- 41) The best cutting fluid for tapping gray cast iron is:
- a) Mineral spirits
 - b) Kerosene
 - c) No cutting fluid at all
 - d) Heavy duty mineral oil

-
- 42) Name the three types of taps found in a tap set:
- a) Taper, truncated, topping
 - b) Taper, plug, bottoming
 - c) Bottoming, truncated, dry seal
 - d) Plug, dry seal, bottoming
- 43) Which of the following statements will **not** prevent tap breakage?
- a) The tap drill size creates a 75% thread
 - b) The tap and material are have lubrication
 - c) The tap drill creates a 95% thread and the hole is drilled to the full thread depth found on the print
 - d) The hole is drilled deeper for chip accumulation
- 44) What is the correct tap drill for a 3/4-14 NPT (pipe thread)?
- a) 7/16 inch diameter drill
 - b) 23/32 inch diameter drill
 - c) 1 1/2 inch diameter drill
 - d) 59/64 inch diameter drill

Basic Milling Operations

- Minimum table movement that can be measured with the hand dial on a vertical milling machine
- Proper procedure for milling a slot
- Procedure for using an edge finder and diameter compensation
- Part of a universal vertical milling machine the table rests upon
- Type of end milling cutter capable of plunge cutting a hole

-
- 45) Which of the following types of end mills is capable of plunge cutting a hole?
- a) Three fluted gashed end mill
 - b) Two fluted end mill
 - c) Four fluted gashed end mill
 - d) Four fluted center cutting end mill
 - e) Both b and d are capable of starting a hole
- 46) The hand dial found on the table of a vertical milling machine has a resolution of:
- a) 0.001 inches
 - b) 0.0001 inches
 - c) 0.010 inches
 - d) 0.100 inches
- 47) An edge finder has a tip diameter of 0.200 inches. What distance must the table move to align the center of the edge finder to the edge of the workpiece?
- a) 0.200 inches
 - b) 0.100 inches
 - c) 0.400 inches
 - d) 0.050 inches
- 48) The table of a vertical milling machine rests on the:
- a) Column
 - b) Spindle
 - c) Saddle
 - d) Head

-
- 49) Which of the following is the best example for milling a 0.375-inch slot on a vertical milling machine?
- a) Use a 0.375-inch diameter end mill and take the cut in one pass
 - b) Use a 0.250-inch diameter end mill and take two passes each overlapping one another
 - c) Use a 0.125-inch diameter end mill and take three passes each overlapping one another
 - d) Use a 0.250-inch diameter end mill for a roughing cut and a 0.375-inch diameter mill for a finishing cut

Clamping and Vise Applications

- Proper clamping location and setup for clamping work directly on the table of the vertical mill
- Procedure for clamping work in a vise and ensuring even seating
- Proper procedure and vise component used for lining up the vise on a vertical milling machine
- Most accurate way to align a milling machine vise
- Most commonly used workholding device on the vertical milling machine

- 50) To accurately align a vise mounted on a table of a vertical milling machine perpendicular to the column, the vise should be aligned with:
- a) Machinists square
 - b) Dowel pins
 - c) Dial indicator against the fixed jaw
 - d) Dial indicator against the moveable jaw
 - e) Dowel pins against the hold down slots

- 51) The most commonly used workholding device on the vertical milling machine is a:
- a) Hold down clamp
 - b) Vise
 - c) Rotary table
 - d) Dividing head

-
- 52) To ensure even seating and to combat any tipping action caused by the moveable jaw, the best practice is to:
- Use gage pins underneath the parallels
 - Strike the workpiece softly with a dead blow hammer and test the parallels for movement
 - Use paper shims underneath the parallels and underneath the workpiece
 - Mount the workpiece on parallels and tighten the vise very tightly with a leverage bar
- 53) When using hold down clamps to clamp work on the milling machine, the best setup that provides even clamping pressure is to:
- The T-bolt is closer to the work than to the step block and at a 3 degree angle tilted down
 - The T-bolt is the same distance from the work and the step block parallel to the table
 - The T-bolt is closer to the step block than to the work and the clamp is angle up toward the work for maximum pressure
 - The T-bolt is the same distance from the work and the step block and is set at a three degree angle titled up

Milling Operations Setup

- Column orientation to the machine table for accurate boring operations
- Three axes of a vertical mill, the direction of each axis and orientation of each axis for a properly trammed vertical milling machine
- Procedure for centering an end mill or slotting saw over a round shaft
- Use of layout lines when performing milling operations
- Rationale for laying out a workpiece
- Milling operation that applies a sine bar during set up

-
- 54) The X-axis on a vertical mill represents _____ table movement. The Y-axis on a vertical mill represents _____ table movement. The Z-axis represents _____ movement of the spindle.
- a) Longitudinal, vertical, Crossfeed
 - b) Longitudinal, Crossfeed, vertical
 - c) Vertical, Crossfeed, longitudinal
 - d) Crossfeed, longitudinal, vertical
- 55) To tram the head of a vertical mill properly, the spindle (or Z-axis) must be perpendicular to the:
- a) X-axis only
 - b) Y-axis only
 - c) X-axis and Z-axis
 - d) Z-axis and Y-axis
 - e) X-axis and Y-axis
- 56) Which of the following **is not** a function of layout lines?
- a) Identifies which side machining is to take place
 - b) Aligns cutting tools
 - c) Prevents machining errors and allows for finishing stock
 - d) Measures parts within 0.0001 inches
 - e) Aids in the visualization of the part to be machined
- 57) A shaft has a two-inch diameter. The milling cutter has a diameter of 0.250 inches. The machinist has touched off at the side (not the top) of the shaft and has raised the milling cutter to clear the part. How far must the table be moved to center the milling cutter over the shaft?
- a) 2.125 inches
 - b) 1.125 inches
 - c) 2.250 inches
 - d) 1.250 inches

-
- 58) To bore a hole perpendicular to the face of the workpiece, the machine table should be _____ to the spindle.
- a) Tangent
 - b) Parallel
 - c) Perpendicular
 - d) Offset at 45 degrees
- 59) Which of the following tools is the most accurate tool for making the preparatory setup for milling an angle on a workpiece?
- a) Machinist square
 - b) Sine bar
 - c) Angle set
 - d) Combination set
 - e) Adjustable parallels

Process Improvement

- Effect of grinding the wrong primary clearance angle on a milling cutter
- 60) What effect will a very small primary clearance angle have on the cutting action of a milling cutter?
- a) The cutter will cut efficiently and provide better wear characteristics
 - b) The cutter will dig into the workpiece on the first pass regardless of the depth of cut
 - c) The back of the land will rub on the work and cause poor cutting action
 - d) The cutter will chatter leaving a poor surface finish

Tool Holding Applications

- Type of spindle most commonly found on a Bridgeport milling machine
- Proper procedure for removing an arbor or collet from the spindle using the drawbar

-
- 61) What type of spindle taper is most commonly found on a Bridgeport milling machine for hold collets?
- a) Jarno taper
 - b) Morse taper
 - c) R-8
 - d) 5-C
 - e) Brown & Sharpe
- 62) To remove a collet from the spindle of a vertical milling machine, the drawbar should be:
- a) Tighten the drawbar one-quarter turn and tapped with a dead blow hammer
 - b) Loosen the drawbar a few turns and tap the top of the drawbar with a dead blow hammer to release the taper then unscrew the drawbar
 - c) Unscrew the drawbar completely and pry the collet out with a small pry bar
 - d) Loosen the collet and tighten the drawbar then hit the top of the drawbar with a dead blow hammer

Milling Machine Components

- Identify the parts of a vertical milling machine

Use the diagram shown on page 32 to identify key components of a vertical milling machine.

- 63) Which of the following vertical milling machine components is labeled as 1?
- a) Knee
 - b) Column
 - c) Table
 - d) Knee lock
 - e) Head

-
- 64) Which of the following vertical milling machine components is labeled as 5?
- a) Table traverse handle
 - b) Quill
 - c) Head
 - d) Table
 - e) Ram
- 65) Which of the following vertical milling machine components is labeled as 9?
- a) Quill feed hand lever
 - b) Vertical traverse lever
 - c) Crossfeed handle
 - d) Table traverse handle
- 66) Which of the following vertical milling machine components is labeled as 7?
- a) Crossfeed handle
 - b) Table traverse handle
 - c) Vertical traverse handle
 - d) Table traverse lock
- 67) Which of the following vertical milling machine components is labeled as 12?
- a) Column
 - b) Table
 - c) Saddle
 - d) Table
- 68) Which of the following vertical milling machine components is labeled as 11?
- a) Head
 - b) Knee
 - c) Vertical traverse handle
 - d) Table

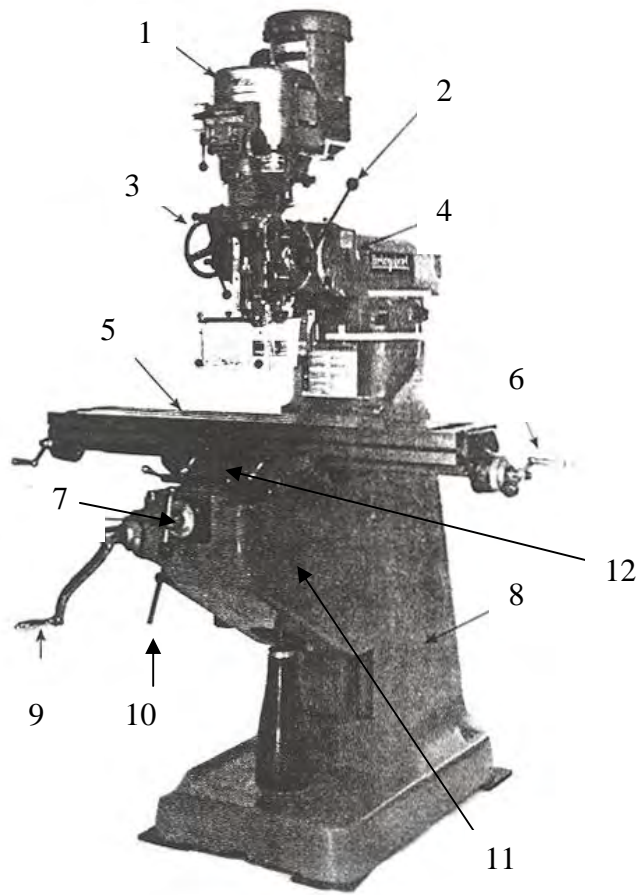

Milling

Sample Test Answers

- 1) B
- 2) A
- 3) D
- 4) C
- 5) D
- 6) B
- 7) B
- 8) A
- 9) D
- 10) B
- 11) C
- 12) A
- 13) A
- 14) B
- 15) C
- 16) C
- 17) E

-
- 18) C
 - 19) C
 - 20) A
 - 21) B
 - 22) A
 - 23) B
 - 24) C
 - 25) D
 - 26) A
 - 27) D
 - 28) B
 - 29) C
 - 30) C
 - 31) C
 - 32) D
 - 33) C
 - 34) B
 - 35) D
 - 36) B
 - 37) A

38) C

39) B

40) A

41) C

42) B

43) C

44) D

45) E

46) A

47) B

48) C

49) D

50) C

51) B

52) B

53) B

54) B

55) E

56) D

57) B

58) C

59) B

60) C

61) C

62) B

63) E

64) D

65) B

66) A

67) C

68) B